



# 1650H

## "CLASSIC" PUSH-PULL TUBE TYPE ULTRA-LINEAR OUTPUT TRANSFORMERS

- Designed for push-pull tube output circuits.
- Enclosed (shielded), 4 slot, above chassis Type "X" mounting.
- Frequency response 30 Hz. to 30 KHz. at full rated power (+/- 1 db max. - ref. 1 KHz) minimum.
- Insulated flexible leads 8" min.
- Manufactured with plastic coil forms for coil support and insulation.
- Typical applications - Push-Pull: triode, Ultra-Linear pentode, pentode and tetrode connected audio output.
- Due to the unique interleaving of the windings BOTH secondary windings must be engaged to meet specifications (see hook-up diagrams below).
- Suggested tube types: 6L6GC, 807, 5881, EL34

ELECTRICAL SPECIFICATIONS	
Characteristic	Typical
Input Impedance	6600 Ohms
Output Impedance	4, 8 & 16 Ohms
Output Power	40 Watts
<b>DCR</b>	
Primary Brown-Red	68.0 Ohms
Primary Red-Blue	77.0 Ohms
Secondary Black-Green	0.160 Ohm
Secondary Black/Yel-Yel	0.272 Ohm
<b>Inductance   Impedance</b> @ 60Hz, 10.0V OC	
Primary Brown-Red	245H   108KOhm
<b>Leakage Inductance</b> @ 60Hz, 10.0V SC	
Primary Brown-Red	10.60mH
Dielectric Strength 2000Vrms	
Temperature Range -40 To 105°C	

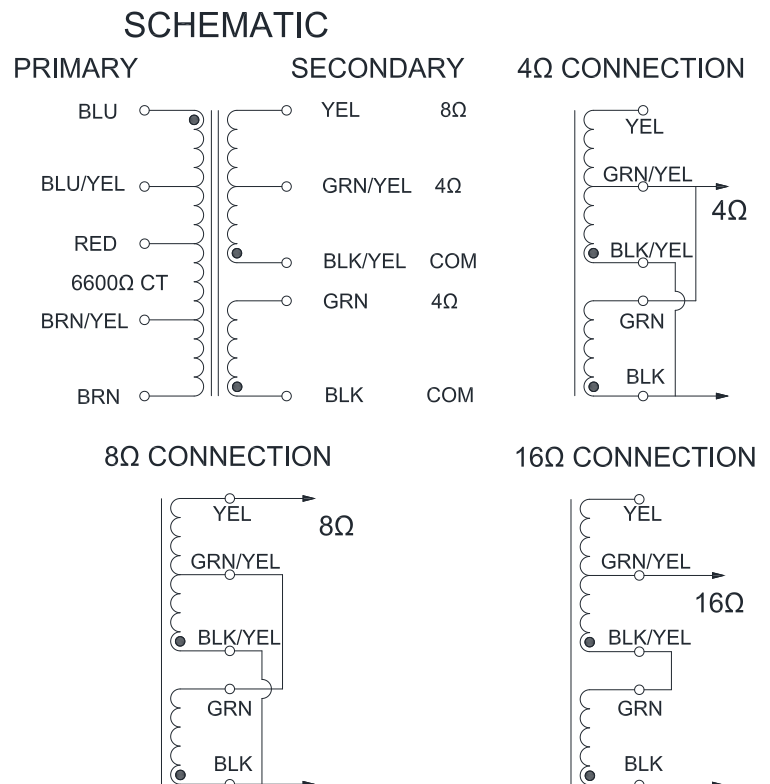

### LABEL:

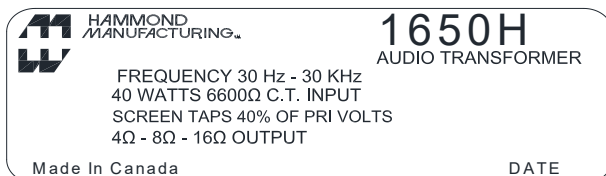

Note: The above examples of possible combinations are to help you narrow down the choices of transformers for your favorite tube types. How you operate the tubes (push-pull, push-pull parallel, ultra-linear, class, B+, bias, operating points, etc.) will change optimum plate to plate load 4040 watts manufacturer's technical data sheets should be consulted first, before making a decision on a proper output transformer.

**DIMENSIONAL DETAILS:**

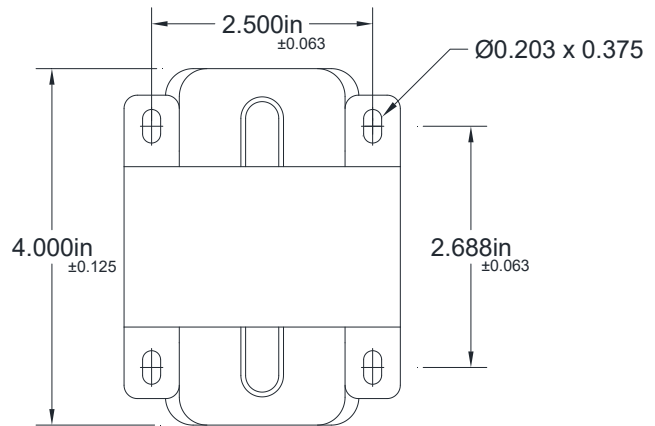
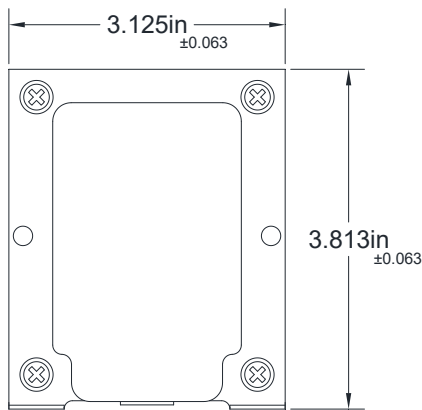
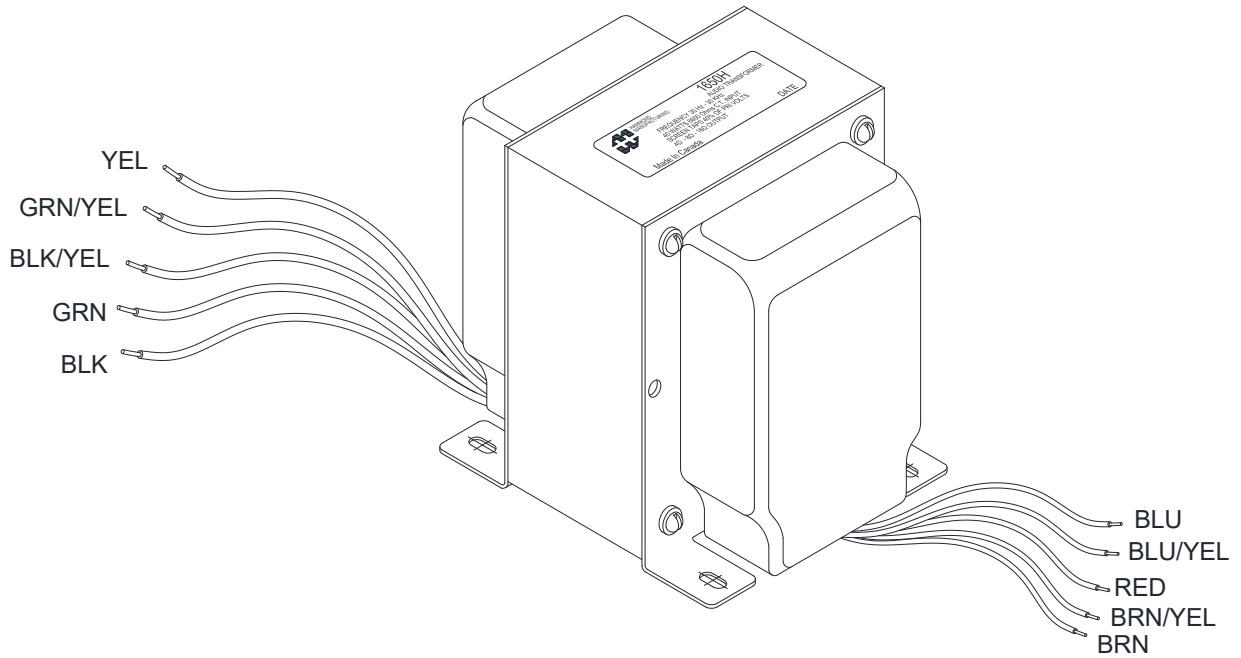

**TEST CONDITIONS**

Measurement Instruments:  
 dScope Series III Audio Analyzer  
 Wayne Kerr 3255B with a 3265B Inductance Analyzer  
 HP 4192a LF Impedance Analyzer  
 Keithley 2010 DVM

\* All graphs input level 27dBu @1.0KHz reference.  
 \*\*The results are typical and are subject to normal manufacturing and electrical tolerances.

**TYPICAL TEST CIRCUIT**

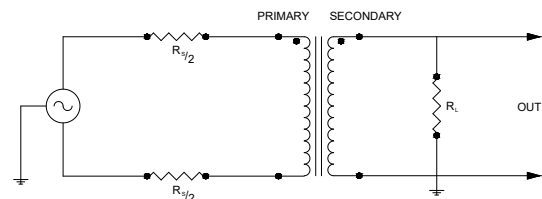

### 1650F Frequency Response RS = 7600 Ohms

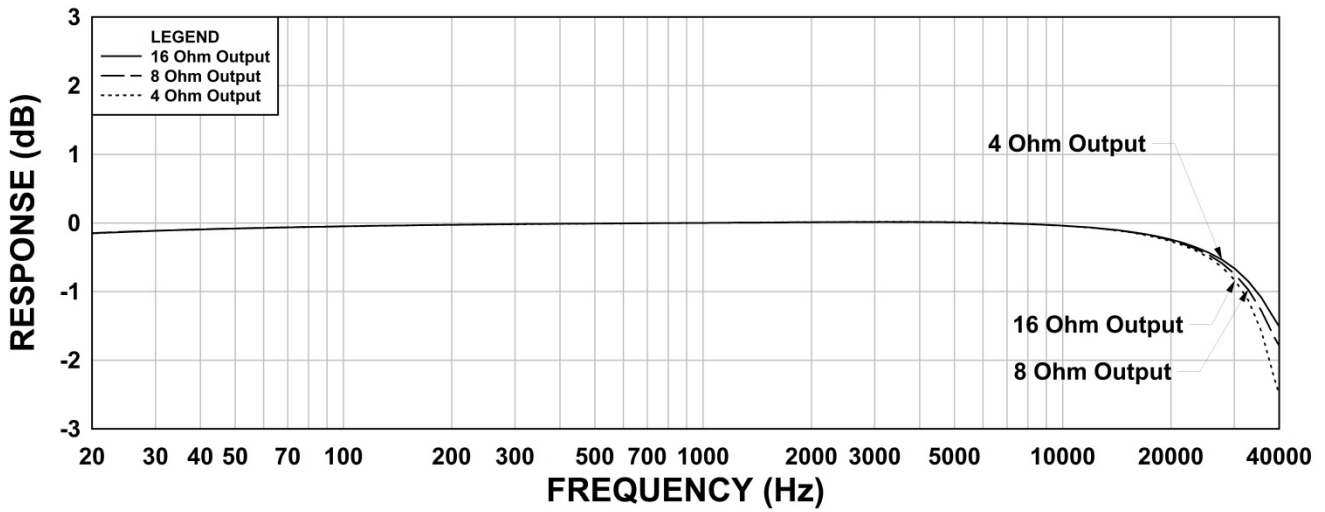

### 1650F Phase Shift RS = 7600 Ohms

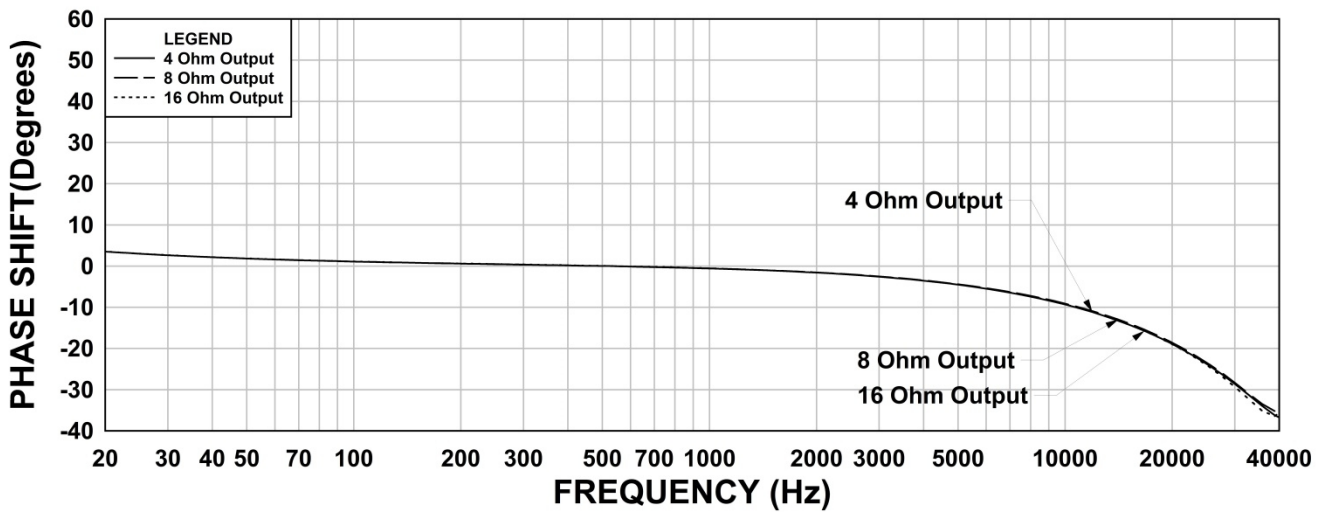

### 1650F THD+N RS = 7600 Ohms

